

## Literature and lectures

### Sewerage System technology in upheaval



University Stuttgart

report regarding the settlement water economy

Volume 140

### Design and construction of the vacuum sewerage system

Dipl.-Ing. R. Schluff, Kiel/Heikendorf

## List of contents

### 1. Sewage disposal in the rural areas

- 1.1 Reasons for the application of special drainage techniques
- 1.2 Costs for the common sewerage system
- 1.3 Possibility for a cost reduction of the sewerage system in the rural area

### 2. History

### 3. Components of the vacuum sewerage system

### 4. Function of the vacuum sewerage system

### 5. Catchment areas of the vacuum sewerage

### 6. Domestic shaft with interface valve

- 6.1 Requirements to the service dependability and the construction of the domestic shaft

### 7. The pipe network

- 7.1 Determination of the pressure stage with the PE-HD-pipe
  - 7.1.1 Sample of calculation for the PE-HD-pipe
- 7.2 Calculation of the pipe network
  - 7.2.1 Sample of calculation

### 8. Vacuum pumping station

**8.1 Pumping station with hydraulically delivery****8.2 Function****8.3 Calculation and construction of a pumping station in which the sewage is delivered via sewage pumps****8.3.1 Calculation of the vacuum pump****8.3.2 Amount of vacuum pumps****8.3.3 Laying of the pumps according to basic and top usage****8.3.4 Construction characteristics of the vacuum pump****8.3.5 Calculation of the sewage pumps****8.4 Calculation of a pumping station in which the sewage is pneumatically delivered****8.4.1 Function****8.4.2 Calculation of the vacuum pumps****8.4.3 Calculation of the compressors****8.4.4 Calculation of the necessary flushpressure in the pressure pump****9. Surveillance and control of the vacuum sewerage system****9.1 Surveillance****9.2 Control****10. Costs of production****10.1 Deduction rates****10.1.1 Pipe network****10.1.2 Domestic shafts****10.1.3 Pumping stations****11. Service costs****11.1 Energy costs****11.2 Costs for repair****11.3 Personnel****Literature****1. Sewage disposal in the rural areas****1.1 Reasons for the application of special drainage techniques**

There are several reasons for the application of special drainage techniques. Mainly though the reason of cost reduction.

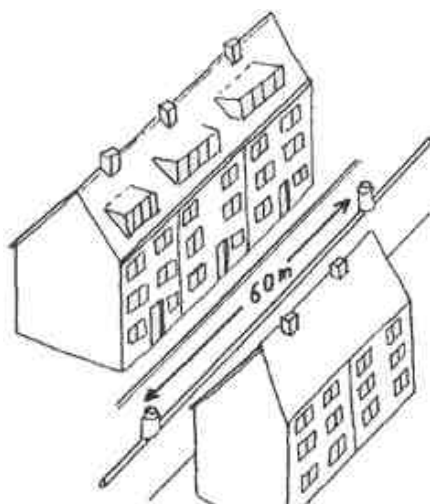
**W H Y ?****1.2 Costs for the common sewerage system****a) in the city area**

Connected inhabitants of a reach of 60 m length.

Building: 1. Road side:

3 houses x 2 units x 4 floors = 24 units

Building on the 2nd road side:

3 houses x 2 units x 4 floors = 24 units

Total 48 Units x 3 J = app. 150 l

Inhabitants per running meter reach:

150 : 60 = 2,5 l/m

Cost per running meter reach

750,00 DM

**Costs per inhabitant 750: 2,5 = 300,00 DM / l**

**b) in the village (rural area)**

Connected inhabitants of a reach of 60 m length.

Building: 1. Road side 2 units

Building on the 2nd road side: 1 unit

Total 3 units x 3 l app. 10 E

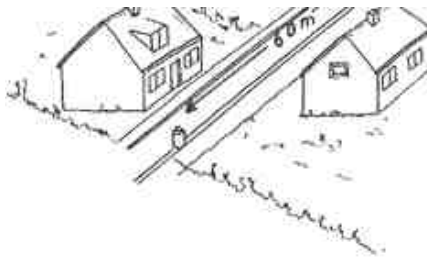

Inhabitants per running meter reach:  
 $10 / 60 = 0,17 \text{ I/m}$

Cost per running meter reach  
 500,00 DM

**Costs per inhabitant  $500 / 0,17 = \text{app. } 3.000,00 \text{ DM / I}$**

**Result.**

**The costs in the village (rural area) are 10 times higher than in the city**

### 1.3 Possibility for a cost reduction of the sewerage system in the rural area

#### Gravity sewerage system

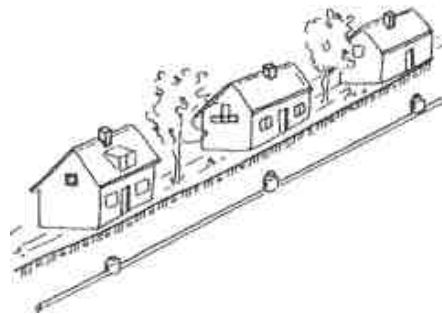

Application only with sufficient country slopes

#### Pressure sewerage system



Predestinated for areas with changing highs and lows as well as scattered settlements

#### Vacuum sewerage system

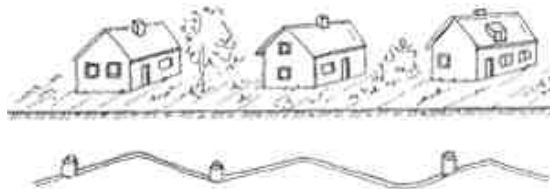

Highest economy in flat areas, high ground water level and poor soil conditions.

## 2 History

The vacuum sewerage system exists now for over 100 years. In the year 1892 already, 500 properties with 15.000 inhabitants of the northwestern suburb of Paris, Levallois-Perret have been connected to the vacuum sewerage system.

Although the experience had been excellent the system fell into oblivion in the course of the decades.

It was not until the year 1959 the Swede Joel Liljendahl continued to develop the vacuum sewerage system and tested it in the in a residential district in the north of Stockholm.

In Germany several communities have been installed a vacuum sewerage systems. But soon after their putting to work the system proved to be very instable. This was mainly based upon the house connections being controlled by a vacuum.

The construction of the pumping stations as well as the form of the pipe system have also not been perfect yet.

**Due to the unsteadiness of the so far used system and the growing problems in the communities with a vacuum sewerage system, the Federal Minister of research and technology ordered the research contract , project no. 02-Wa 8732 having the main task to make the vacuum sewerage system safe.**

An engineering office from Kiel constructed a complete vacuums system in a transparent pipe. With the help of this plant basic possibilities of improvement could be realised for the practical use.

Control and monitoring had been developed. In opposition to all former known constructions the As the principal item a domestic interface valve made of wear resistant PVC with electronically air intake, being necessary for the sewage transport, took place directly via the valve. The amount of air is in addition being accustomed to the necessary air-water-ratio, resulting of the changing vacuums within the pipe network.

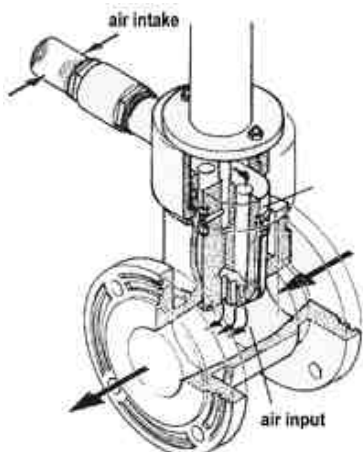

This led to a saving of approximately 60% of the energy costs.

The so far known delivery technique has been improved revolutionarily by the new development.

The valve had been subjected to a very hard endurance test under the addition of expanded plastics, cellulose and sand.

After 300.000 test the valve was still vacuum prove and only small wearout noticeable.

Under the assumption that in a common household for the sewage disposal approximately 3000 switchings a nessesary that result leads to a theoretical service dependability of 100 years.

Further on did numerous test and measured led to the complete new knowledge ans the development of a service dependent dalivery system.

A vacuum pneumatically pumping station has also been newly developed which led to a reduction on service and maintenance costs, the building cost have also been reduced by almost 50 % and the service dependability rose.

The fact that all aircraft, passenger ships and trains do use a vacuum for the disposal of the feces should also been stated in this historical outline.

### 3 Components of the vacuum sewerage system

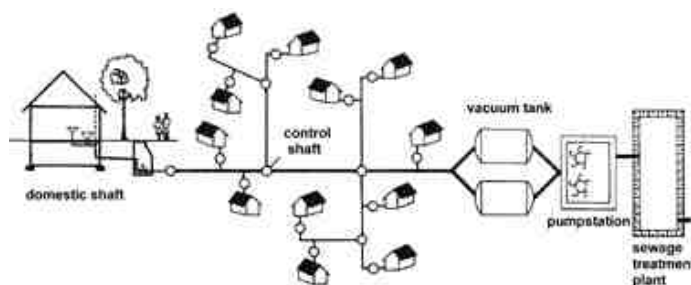

Domestic shaft: in which the sewage is submitted to the pipe network in measured amounts

Pipe network for the transport of the sewage

Pumping station in which the vacuum for the sewage conveyance is produced

### 4 Function of the vacuum sewerage system

The vacuum pumps being situated within the pumping station do produce a vacuum of 0,6 to 0,7 bar in relation to the atmosphere within the sewage tank. The vacuum continuos throughout the pipes up to the domestic shafts. As soon as sewage in a house is produced a control opens a interface valve and the sewage, under the immediate addition of air, is sucked to the pumping station. Air and sewage reach the sewage tanks in thrusts. Are the sewage containers filled, the sewage will be transported to the sewage plant under the aid of the sewage pumps. There the sewage will be further processed.

At necessary manometric delivery heads beginning at 30 m the delivery process will take place pneumatically.

## 5 Catchment area of the vacuum sewerage

In principle the catchment area should not exceed 4 km in the diameter. The pumping station should be seen as the center. The heights and the ending points of the pipelines should in comparison to the pumping station not be lower situated than:

At 2,0 km 0,80 m  
 At 1,50 km 1,20 m  
 At 1,0 km 1,60 m  
 At 0,75 km 2,00 m

In this case the depth of the domestic shafts is to be considered and the total length of the pipes to be included. The transmission of sewage out of higher depth is only possible with the according air outcome control.

Larger areas are to be separated into single areas with independent vacuum pumping stations and to be connected with pressure pipelines. This allows the system to be spread over large regions.

## 6 Domestic shaft with interface valve

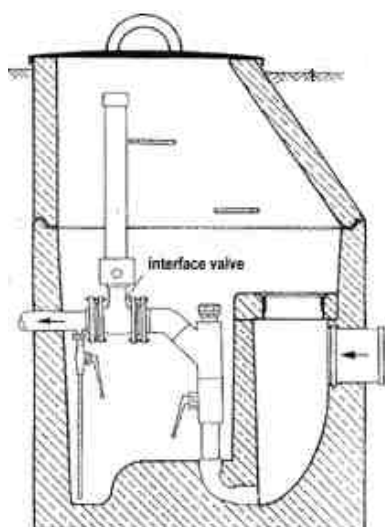

Example : Domestic shaft with electronically controlled valve and automatic air intake

The sewage is being delivered by a gravity system to the pre tank of the domestic shaft. Is the pretank being filled, an electronic sensor opens the interface valve. During the opening air flows into the mixing chamber and is being mixed with the sewage and leaves the valve flowing into the pipe network a water-air mixture. The valve is being closed hydraulically using a contact

pressure of approximately 260 kg.

There are also pneumatically controlled valves, that open and close depending to the vacuum.

### 6.1 Requirements to the service dependability and the construction of the domestic shaft

#### The shaft

Water tight  
 Lift safe  
 Frost safe  
 Simple construction

#### The valve

Free flow to avoid energy loss and clogging up,  
 opening independent of pressure,  
 closing independent of external force,  
 sewage delivery with simultaneous addition of air,  
 long-term durability and freedom from maintenance.  
 250.000 switching are to be ensured according to European Norms

## 7 The pipe network

The supply mains are to be made of PVC hard according to DIN 8061/62 PN 10 or PE-HD according to The pipe material DIN 8074/75 in the cross section DN 65, DN 80, DN 100 and DN 125.

## 7.1 Determination of the pressure stage with the PE-HD-pipe

With the PE-HD pipe the chosen pressure stage has to be considered, since the pipe tends to forming and therefore to constriction of the cross section in dependence to temperature and vacuum. The necessary pressure stage can be taken from the following table.

Here it is to be considered that a temperature of 35 ° shall not be exceeded.

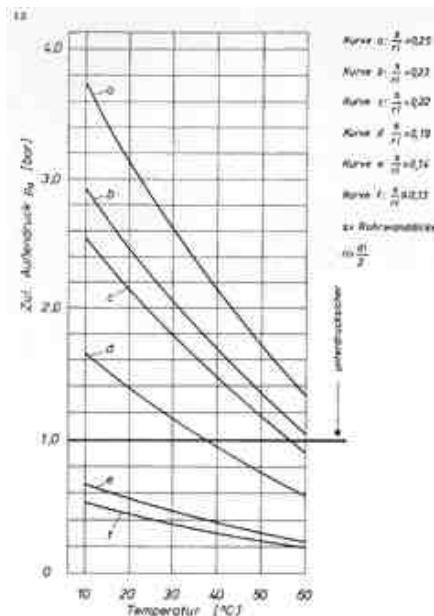

Zulässige Außendrucke bzw. Anwendungsgrenzen bei Unterdruckbelastung für Rohrleitungen aus PE-HD

### 7.1.1 Sample of calculation for the PE-HD pipe

Necessary pipe cross section DN 125

Chosen:

PE HD Pipe 125 x 7,1, PN 6  
s = 7,1 mm, di = 110,8 mm

Determination of the curve

oooo di 00110,8000  
ri = ---- = ----- = 55,40  
oooo 2ooooo

oooooooo 7,1  
Curve x = ----- = 0,13  
oooooooo 55,40

The calculated curve value is too low. The calculated is repeated with a higher pressure stage.

Chosen:

PE-HD-pipe 125 x 11,4, PN 10  
s = 11,4 mm, di = 102 mm

oooo di 0000112  
ri = ----- = ----- = 51  
oooo 2ooooo

oooooooo 11,4  
Curve x = ----- = 0,22  
oooooooo 51

### Result

The chosen pipe is vacuum save even at a temperature of 35 °

## 7.2 Calculation of pipe network

At this calculation the following factors are to be taken into account:

### Number of inhabitants

#### Amount of water

Q = 150 L/J/d, foreign water is not necessary to be taken into account

Topoutlet based upon Q/8

$$Q = \frac{000000150}{000008 \times 60 \times 60} = 0,005 \text{ E (l/s)}$$

### Additional value

In the calculation of the pipe network the following factors are of decisive influence:

Addition of the high and low points of the laying form  
 Equality factor of the opening of the domestic interface valves  
 Speed of flowing  
 Vacuum transport  
 As well as a risen sewage at a later risen density in building

Due to empiric evaluations a usable addition of 65 % resulted, with is to be multiplied by Q

$$Fz = 1,65$$

$$Q = 0,005 \times 1,65 \times l \text{ (l/s)} = 0,00825 \times l \text{ (l/s)}$$

### Friction loss hr

#### Value of roughness

The pipes friction losses are calculated on base of the formula from Prandtl-Colebrook.

$$\text{Service value of roughness } kb = 0,25 \text{ mm}$$

#### Pressure line fall Jr

Air inclosures within the pipe and the continously changing pressure based upon the dual phase flowing are multiplied with the empirically determined service factor  
 $fb = 1,5$ .

Determined pressure line fall = Jr x fb

$$hr = \frac{00000l \times Jr \times fb \text{ (m)}}{0000001.000}$$

### Geodatical difference in height Hgeo

It results form the difference in height in between the suction height in the pumping station and the lowest point of the cord, respectively the domestic shaft to be calculated

$$H \text{ geo in m}$$

### Important !

Vacuumpumping stations are economically run at a vacuum of 0,6 bar in relation to the atmosphere. The vacuum at the domestic interface valve should due to safety reasons not exceed 0,3 bar.

The sum of the pipe friction loss and the difference in height should therefore not exceed a value of 3,00 m water column.

### 7.2.1 Sample of calculation

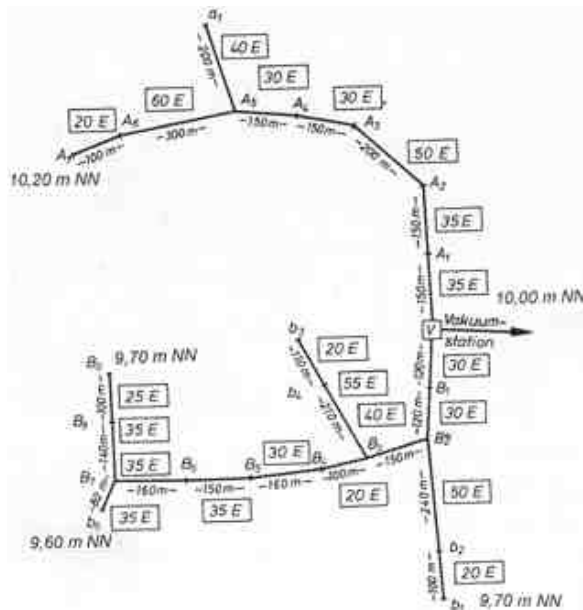

Strecke	Länge	Ein- weiser E 0,00025	Abwasser- anfall l/s	Gesamt- abfluss l/s	Rohr- durch- messer mm	Druck- linien- gefälle ‰	Erhöhtes Druck- linien- gefälle ‰	Rohr- reibungs- verluste h mWS	Bemerkungen
von bis	l m	E	3	4	5	6	7	8	9
A <sub>1</sub> A <sub>2</sub>	100	20	0,165	0,165	65	0,10	0,35	0,075	
A <sub>2</sub> A <sub>3</sub>	300	60	0,495	0,66	80	0,40	0,60	0,180	
A <sub>3</sub> A <sub>4</sub>	200	40	0,33	0,33	65	0,225	0,337	0,087	
A <sub>4</sub> A <sub>5</sub>	150	30	0,247	1,237	80	1,25	1,875	0,281	
A <sub>5</sub> A <sub>6</sub>	150	30	0,247	1,484	80	1,80	2,70	0,405	
A <sub>6</sub> A <sub>7</sub>	200	50	0,412	1,896	80	2,80	4,20	0,840	
A <sub>7</sub> A <sub>8</sub>	150	35	0,288	2,184	100	1,20	1,80	0,270	
A <sub>8</sub> Vak.	150	35	0,288	2,472	100	1,60	2,40	0,360	
								2,418	< 3,0
B <sub>1</sub> B <sub>2</sub>	100	25	0,208	0,208	65	0,10	0,15	0,015	
B <sub>2</sub> B <sub>3</sub>	140	35	0,288	0,494	80	0,24	0,36	0,050	
B <sub>3</sub> B <sub>4</sub>	80	35	0,288	0,288	65	0,18	0,27	0,021	
B <sub>4</sub> B <sub>5</sub>	160	35	0,288	1,070	80	0,95	1,425	0,258	
B <sub>5</sub> B <sub>6</sub>	150	35	0,288	1,358	80	1,50	2,25	0,337	
B <sub>6</sub> B <sub>7</sub>	160	30	0,247	1,605	80	2,10	3,15	0,504	
B <sub>7</sub> B <sub>8</sub>	100	20	0,165	1,770	80	2,40	3,60	0,360	
B <sub>8</sub> B <sub>9</sub>	170	20	0,165	0,165	65	0,10	0,15	0,018	
B <sub>9</sub> B <sub>10</sub>	210	35	0,453	0,618	80	0,36	0,54	0,113	
B <sub>10</sub> B <sub>11</sub>	150	40	0,330	2,718	100	1,85	2,775	0,416	
B <sub>11</sub> B <sub>12</sub>	300	20	0,165	0,165	65	0,10	0,15	0,015	
B <sub>12</sub> B <sub>13</sub>	240	50	0,412	0,577	80	0,32	0,48	0,115	
B <sub>13</sub> B <sub>14</sub>	120	30	0,247	1,542	125	0,30	1,395	0,167	
B <sub>14</sub> Vak.	120	30	0,247	1,789	150	0,68	0,68	0,082	
								2,439	< 3,0
zuzüglich h <sub>geo</sub> 10,00 - 9,60 =									0,4
									2,83,9 < 3,0

Vacuum at the pumping station 0,60 bar  
 Subtracting total loss 0,28 bar  
 Remaining vacuum ant the lowest domestic shaft 0,32 bar

The calculation process has itself proven to be correct in communities in which the most houses are connected to one pipe cord and only short pipe cords are branching the pipe network.

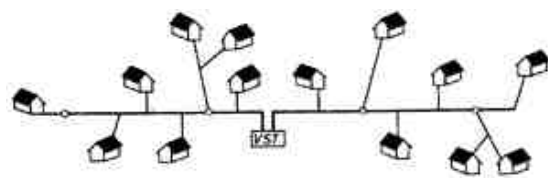

Big branchings and especially when the areas to be drained are situated in various heights, it makes sense to split them up.  
 The splitting up can lead to lower costs and furtheron give the possibility to run the system with varying control on a energy saving level.

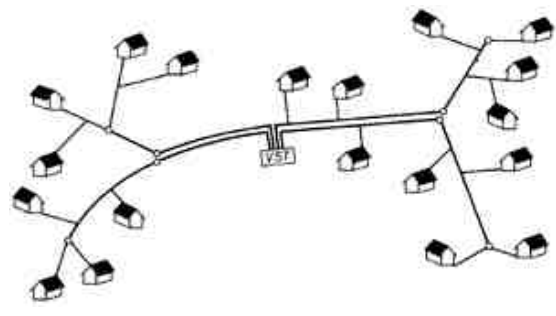

## 8 Vacuum pumping station

There are two possibilities which are mainly distinguished by the type of building and the delivery level.

### 8.1 Pumping station with hydraulically delivery

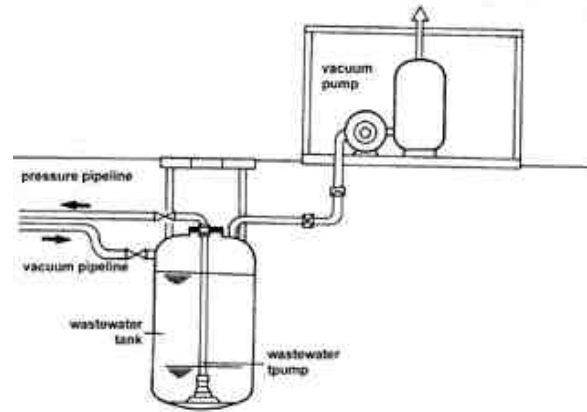

In front of the pumping station there are at least two sewage tanks with approximately 10 to 12 m<sup>3</sup> of content. In these tanks the sewage pumps are installed.

In a building on top (prefabricated garage) the vacuum pumps are installed.

## 8.2 Function.

The vacuum pump produces a vacuum in the sewage tank by which the sewage is sucked from the pipe network to the tank. From here on it will be delivered hydraulically to the sewage plant via a pressure pipe.

The possible manometric delivery height is 30 m.

## 8.3 Calculation and construction of a vacuum pumping station in which the sewage is delivered via sewage pumps.

### Building on top

A prefabricated garage is mainly used for the installation of the vacuum pump and the switch and control units

### 8.3.1 Calculation of the vacuum pump

#### Required amount of air

The required amount of air is mainly based upon the following factors

- Number of inhabitants and inhabitant equality values
- Inhabitants per running meter of pipe
- Length of the pipe network
- Difference in height between the pumping station and the lowest area to be sewed.

A formula for calculation that includes the above mentioned factors is not available.

Based upon empirical tests the following calculation basis had been found

Required amount of air

**6 l Air/Inhabitant/Minute**

### 8.3.2 Amount of vacuum pumps

In order to provide full function even in case of repair vacuum stations have to be provided with vacuum reserve pump besides the main pump.

- Vacuum stations at which the required air is to be supplied by one main pump should be supplied with a reserve pump of the same power.
- Vacuum stations at which the required air is to be supplied by 2 main pumps should be supplied with one reserve pump with the power of one of the main pumps.

### 8.3.3 Laying of the pumps according to basic and top rate performance

It is to assume that the sewage will occur in a basic amount continuously throughout a day in between 6:00 and 22:00 o'clock.

This basic amount will be exceeded in top times 3 times daily by over 100 %.

These times are:

06:30 - 08:30 o'clock

11:30 - 13:30 o'clock

18:00 - 20:00 o'clock

To prevent a peak performance power requirements the pumps are to be laid in a way that - e.g. if two main pumps are chosen - the basic performance can be fulfilled by the main pump and only on peak performance points is supported by the second pump.

Basically the calculated amount of air should be spread upon several pumps with lower power.

### 8.3.4 Construction characteristics of the vacuum pump

Vacuum fluid ring pumps are to be preferred. They do produce the vacuum by water in a fluid ring and therefore require no lubrication and maintenance.

### 8.3.5 Calculation of the sewage pumps

The calculation of the sewage pumps is performed according to the work sheets of the ATV

## 8.4 Calculation of a pumping station in which the sewage is pneumatically delivered

### Pumping station with pneumatical delivery

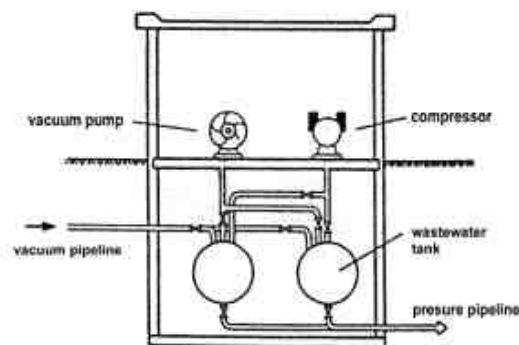

The station is composed of a top and a low part which are to be placed upon each other.

In the lower part (foundation) there are at least two sewage tanks that are run as a vacuum tank as well as a pressure tank. In the top part there are the vacuum pumps and the compressors for the pneumatically delivery.

### 8.4.1 Function

The vacuum pump produces a vacuum of 0,6 to 0,7 bar in relation to the atmosphere in the sewage tank. The sewage from the connected houses will be sucked from the vacuum pipe to the sewage tank. If one sewage tank filled the vacuum line of the area closes down. The pressure pipe to the sewage plant is opened. The sewage is blown out of the tank by compressors. During this process the second tank takes over the function in order to keep up the system.

The possible monometric delivery height is app. 120 m and allows it to cross longer distances on the way to the sewage plant.

### 8.4.2 Calculation of the vacuum pumps

#### Required air

The same as at the hydraulic pumping stations

#### Quantity of vacuum pumps

The same as at the hydraulic pumping stations

#### Laying of the pumps according to basic and top rate performance.

The same as at the hydraulic pumping stations

### 8.4.3 Calculation of the compressors

In opposition to the hydraulic delivery in which the sewage is delivered by sewage pumps here the delivery is performed by compressed air. The sewage having been collected in the tanks is blown out.

For the compressors the following factors are to be taken into account.

Uprising Sewage  $Q_s$

Sewage Contents of the tank  $V_k$

Time to fill tank  $t_f$

Time loss  $t_v$  (Switching time of the valves, neutralisation time of the pressure relation)

Blowing out time  $t_a$

Pressure height

Volume being blown out  $Q_{ab}$

#### Remark

For the calculation please see the book "Unterdruckentwässerung -Abwasserbeseitigung im ländlichen Raum (Schluff)  
Special attention should be made to the calculation of the sewage pressure pipe due to the dual phase flow.

### 8.4.4 Calculation of the necessary flushpressure in the pressure pipe

Compressed air flushed closed sewage pipes are a safe possibility for the transport of sewage. The procedure is therefore applicable for far out areas to be connected to central sewage plants. The pressure flush leads to a shorter period of time for the sewage to stay in the pipe. After every pneumatically flush or blow procedure air comes into the pipe which on one hand assists the delivery of the sewage but on the other hand handicaps the flow tremendously. Although the behavior of the air inlock is a result of coincidences the filling stage in the pipe are determinable. These are relevant for the calculation . Larger air inlocks to collect behind the high points in the falling parts of the pipe. In these parts there is the free level sewage situated. Free level sewage respectively partly filling stages are found in all parts of the pipe network in which the pipe falling (J) is higher than the pressure line falling at complete filling (Jv)

Under the assumption of stational equal constitutions in these parts of the pipe the energyline, respectively the pressure line runs equal to the pipe axis, which leads to a higher energy loss than there is in the parts of the pipe network without air inlocks. This results is lower flowing capacity in the pipe sections with air inlocks which has to be compensated by higher flushing pressure.

Under circumstances although the total filling condition might be authoritative for the allocation of the flushing pressure.

Starting at a specific flowing speed a air outcome is produced in which the flowing of the complete air inlock is set into movement and is being transported.

The formula for the minimum flowing speed at which the pipe is surely ventilated

$$VK_{min} = (0,825 + 0,25 \sqrt{J}) \sqrt{g} \times d$$

From Wisner, Mohse, Kouwen "Removal of air from water lines by hydraulic means"

By ignoring the slopes the following minimum flowing speeds for the various pipe diameters are resulting:

1. DN 80 / VK min =  $(0,825) * 9,81 * 0,08 = 0,75 \text{ m/s}$
2. DN 100 / VK min =  $(0,825) * 9,81 * 0,10 = 0,82 \text{ m/s}$
3. DN 125 / VK min =  $(0,825) * 9,81 * 0,125 = 0,91 \text{ m/s}$
4. DN 150 / VK min =  $(0,825) * 9,81 * 0,150 = 1,00 \text{ m/s}$

$$5. \text{ DN } 200 / \text{ VK min} = (0,825) * 9,81 * 0,20 = 1,16 \text{ m/s}$$

During the flushing process interstationaire relations are present. Further on long sections are developed in which a water air mixture is present. A more precise determination of the outlet is therefore not possible.

In the following formula is under the prerequisite of separation areas in between water and air the mathematical relation between outlet speed  $v$  and flushing pressure  $psp$  stated.

$$v = \sqrt{\frac{2 \times d \times (psp + \gamma \times g \times L \times J)}{\gamma \times \delta \times L}}$$

- d: pipe diameter
- $\delta$ : Water density
- g: falling acceleration
- L: Length of the water part to be flushed
- J: incline (positive at slope  
negative at grade)
- $\gamma$ : friction value

A flushing speed of  $v = 1,0 \text{ m/s}$  is to be aimed at.

## 9 Control and monitoring of the vacuum sewerage system

The central control and monitoring of the vacuum sewerage system is of relevant importance for the security and the economical work of the system. Hereby surveillance and control are distinguished.

### 9.1 Surveillance

The surveillance includes the independent transmission of data regarding the condition and process on the functions in the domestic connection and the pumping station as there are e.g.

#### Reports from the domestic shaft:

- Clogging in the inlet
- Valve doesn't close
- Water in the domestic shaft

#### Reports from the pumping station

- Vacuum too low
- No pressure
- Power failure

The data will be transmitted to a monitor and then printed on a printer. The report office, e.g. the sewage plant, is at anytime informed on all statuses of function of every domestic connection and pumping station. Reported failures include detailed information on place, type, size and tools required for the repair. A failure can immediately be localized and repaired.

### 9.2 Control

Controls are processes in which the system is actively interfered by orders, e.g.

- Adjustment and changing of the valve's opening time
- Report on the punctual varying pressure proportions within the system and balancing to a medium value
- Report of the water amount for a connection for a certain period of time and printing the invoice.

## 10 Costs of production

The production costs of the sewerage building sites, the surface opening and its restoration can vary in accordance to local prerequisites.

For a rough cost determination a price of DM 130,00 per excavation and pipe lines should be based upon.

Almost no differences are within the function elements of the system. They are amounting to  
For one domestic shaft incl. Control and

- monitoring technology approximately. DM 4.500,00
- Pumping station, ready to use approximately DM 300.000,00
- For brick laying, roof approximately DM 30.000,00

## 10.1 Deduction rates

According to ATV work group 1.12

### 10.1.1 Pipe network

80 - 100 years, depending on the care at pipelaying

### 10.1.2 Domestic shafts

Concrete shaft  
and PVC parts approximately 2.500,00 DM 50 years) Average value  
Valve and control approximately 2.000,00 DM 25 years) app. 35 years

### 10.1.3 Pumping stations

Building part 190.000,00 DM 50 years  
Machine and mov.parts 80.000,00 DM 15 years  
Sewage and pressure tank 30.000,00 DM 40 years

## 11 Service costs

### 11.1 Energy costs

For collecting of the sewage in the vacuum system  
depending on the width of the area between 0,10 - 0,35 DM/m<sup>3</sup>

For further delivery to the sewage plant depending on  
distance and differences in height 0,15 - 0,35 DM/m<sup>3</sup>

### 11.2 Costs for repair

Regarding the electronically controlled systems we do have facts on 19 plants for a time period of 10 years. This leads to the knowledge that the maintenance expenditure is not or only in low numbers necessary. Therefore he should not be estimated higher than 0,1 - 0,2 % of the function elements.

### 11.3 Personnel

With the electronically controlled plant it had proven itself to not set up maintenance contracts. What for?

It makes sense so to have the oil changing in the compressors being taken care of twice a year. This should be performed by a competent company for a fixed price. This price should be approximately 500.00 - 600,00 DM per anno.

A control of the pumping station and the domestic shafts can be performed on sideline base or by the employee in the sewage plant. This should not exceed 200,00 - 300,00 DM per month.

The training of the personnel takes place in two day's courses. In these courses the necessary knowledge is submitted.

## Literature

Entwurf eines Arbeitspapiers: Unterdruckentwässerung  
Planungs-, Bau- und Betriebsgrundsätze  
Arbeitsgruppe 1.1.6  
Korrespondenz Abwasser 2/1985

Unterdruckentwässerung Neue Erkenntnisse führen zu einem

betriebssicheren Fördersystem  
Dipl.-Ing. Reinhold Schluff, Heikendorf  
Abwassertechnik 4/1986

Arbeitsbericht der ATV "Besondere Entwässerungsverfahren"  
Druckluftgespülte Abwassertransportleitungen  
Planungs-, Bau- und Betriebsgrundsätze  
Korrespondenz Abwasser 1/1987

Unterdruckentwässerung - Abwasserbeseitigung im ländlichen Raum  
R. Schluff, Heikendorf 1990

ATV Arbeitsblatt A 116, September 1992  
Besondere Entwässerungsverfahren  
Unterdruckentwässerung - Druckentwässerung

**Copyright R. Schluff, Heikendorf**

[back](#)

www.vakuumkanalisation.de • www.underdruckentwaesserung.de • www.vacuumschwermetalle.com •• Tel.: 0431/24405 • Fax: 04343/499107